



PSK 1000 I

PSK

ENG	Installation and operating instuction	4
DEU	Montage- und Bedienungsanleitung	7
NLD	Montage- en gebruikshandleidingen	10
FRA	Installation et mode d'emploi	13
POL	Instrukcja montażu i obsługi	16



BE	Flamco Belux Monnikenwerve 187/1 B -8000 Brugge	+32 50 31 67 16	info@flamco.be
CH	Flamco AG Fännring 1 6403 Küsnacht	+41 41 854 30 50	info@flamco.ch
CZ	Flamco CZ Evropská 423/178 160 00 Praha 6	+420 602 200 569	info@flamco.cz
DE	Flamco GmbH Steinbrink 3 42555 Velbert	+49 2052 887 04	info@flamco.de
DK	Flamco Tonsbakken 16-18 DK-2740 Skovlunde	+45 44 94 02 07	info@flamco.dk
EE	Flamco Baltic Löötsa 4 114 15 Tallin	+372 56 88 38 38	info@flamco.ee
FI	Flamco Finland Ritakuja1 01740 Vantaa	+358 10 320 99 90	info@flamco.fi
FR	Flamco s.a.r.l. BP 77173 95056 CERGY-PONTOISE cedex	+33 1 34 21 91 91	info@flamco.fr
HU	Flamco Kft. H-2040 Budaörs, Gyár u. 2 H-2058 Budaörs, Pf. 73	+36 23 88 09 81	info@flamco.hu
NL	Flamco B.V. Postbus 502 3750 GM Bunschoten	+31 33 299 75 00	support@flamco.nl
PL	Flamco Sp. z o. o. ul. Akacjowa 4 62-002 Suchy Las	+48 616 5659 55	info@flamco.pl
SE	Flamco Sverige Kungsgatan 14 541 31 Skövde	+46 500 42 89 95	vvs@flamco.se
UAE	Flamco Middle East P.O. Box 262636 Jebel Ali, Dubai	+971 4 881 95 40	info@flamco-gulf.com
UK	Flamco Limited Washway Lane- St Helens Merseyside WA10 6PB	+44 1744 74 47 44	info@flamco.co.uk

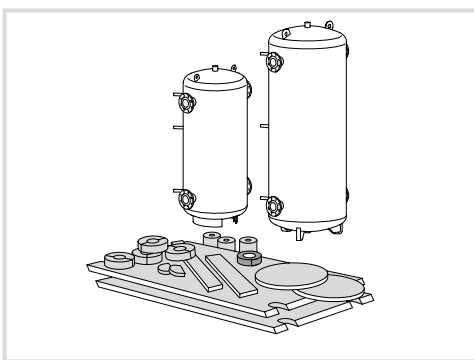
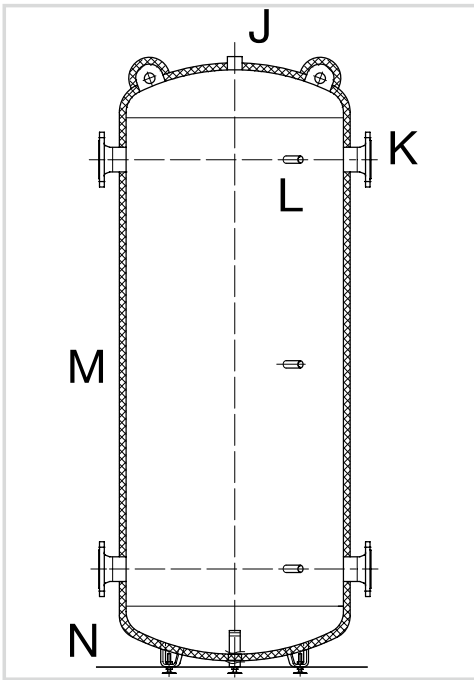

A

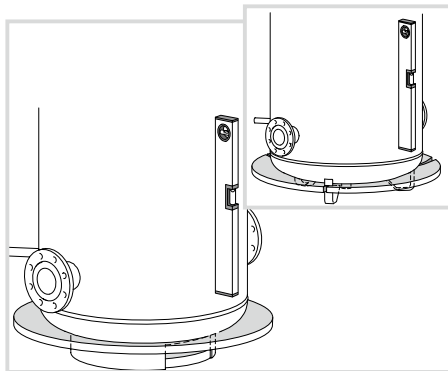

B

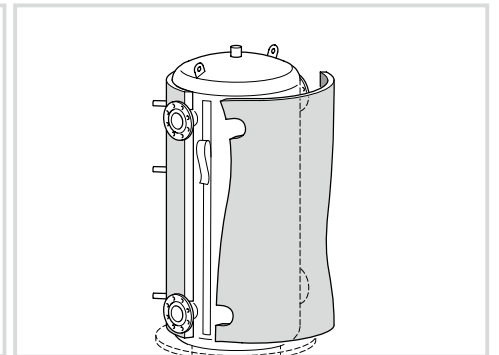

C

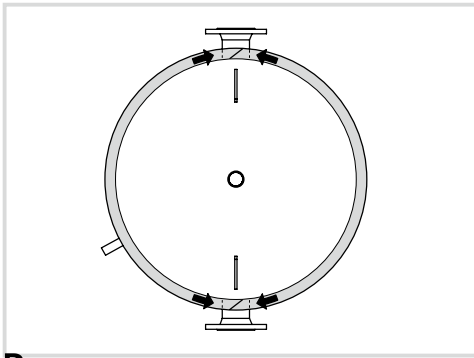

D

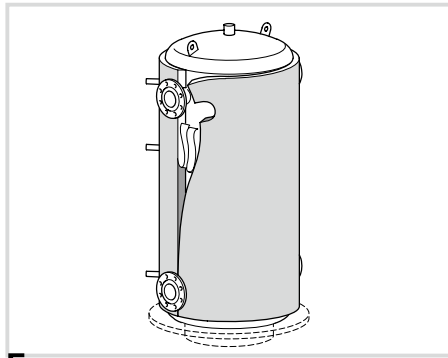

E

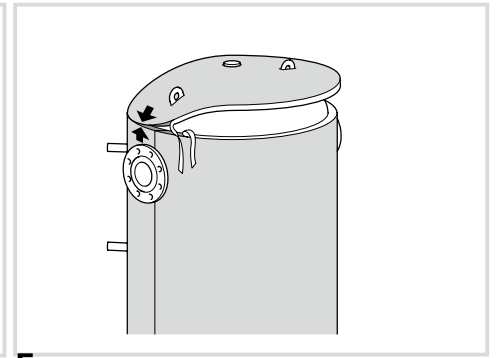

F

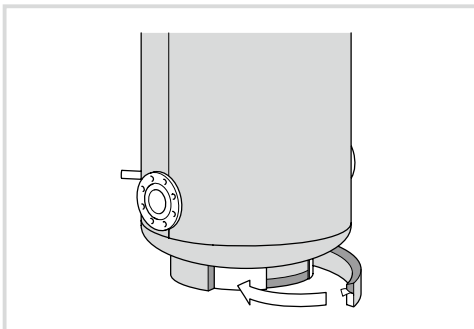

G

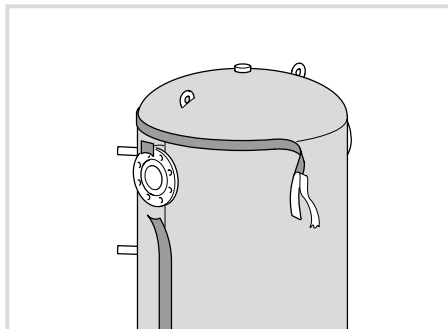

H

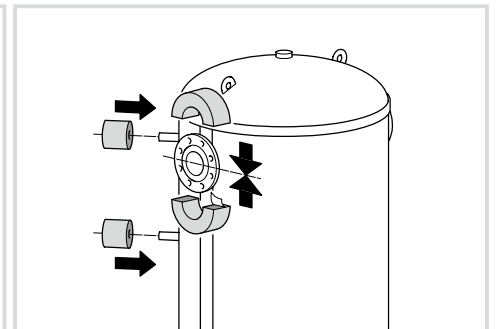

I



1. General

Can be used in all closed, water-based cooling systems. Rugged and assembly-friendly construction, with adjustable feet (up to 2000 l) for a fast and secure setup. Externally coated with anti-corrosion epoxy primer, untreated inside. Series set up possible, not suitable for potable water.

Conditions for use:

Maximum storage vessel operating pressure: 6 bar.

Maximum storage vessel operating temperature: -20 / +50 °C (253/323 K).

Insulation (to be ordered separately):

Elastomer insulation with high accuracy of fit as an installation-friendly kit. The insulation has a high water vapour diffusion resistance and a sealed cell structure for low convection.



Safety regulations

Read these instructions carefully before commencing installation. For any additional questions, please consult our customer service department (see contact details).



Warning: do not expose the insulation to fire or naked flames as it is flammable (fire category B1 to DIN 4102).

Installation, commissioning and maintenance must be carried out by qualified installers in accordance with local regulations (including EN 1717, DIN 1988, EN 12828, VDI 2035, also regulations of the local provider).

Measures for the safe collection or drainage of water in the event that water escapes from the storage vessel are to be taken to avoid water damage.



Warning: Do not use any pliers, tension belts, etc. when installing the insulation!



Warning: Hot water may escape from the safety valves or when draining the storage vessel; risk of scalding. The system operator must prevent untrained persons from being put at risk.



For further technical data see type plate.

1.1 Legend

J. System connection/ventilation	x
K. System connection (flow and return)	x
L. Thermometer/sensor connection	x
M. Insulation	x (to be ordered separately)
N. Adjustable feet.	(up to 2000 l)

2. Commissioning

The storage vessel may be placed in frost-free areas only, on surfaces that are capable of supporting the weight of the fully filled storage vessel. Sufficient space should be allowed for future installation and to service the system etc.

Avoid exceeding the permissible operating conditions. The nominal capacity of the buffer tank is to be taken into consideration when selecting the size of the expansion vessel.

Safety valves should be installed so that they are easily accessible for regular checks and are to be fitted with drain connections.

The storage vessel or storage vessels must be connected and equipped so as to prevent the formation of internal air cushions or a vacuum.

The instructions provided with accessories apply separately. Finally, attach the supplied type plate in a visible position.

2.1 Installing the cold insulation (optional)

This insulation can only be used for PSK.

Please note the following points in order to achieve optimal insulation. The installation procedure is to be followed as described:

- The storage vessel must be free from dirt and grease.
- A minimum of two persons are required to install the insulation.
- Ensure that the outer skin is not damaged.
- The butt joint surfaces of the insulation must be clean and bonded flush with each other.



Applying the insulation:

1. Check that the insulation kit is complete **(A)**.
2. Set up and align the storage vessel **(A)**.
3. Place the shaped insulation panel for the lower dished end inside the support ring (for 500 – 750).
4. Lay the shaped insulation panel for the lower dished end around the support skirt (500 - 750) or over the vessel feet (for 1000 – 3000) **(B)**.
5. The double-sided adhesive tape included in the kit is to be applied vertically to the vessel (150 mm to the left and right of the insulating jacket seam) **(C)**.
6. Place and align the insulation over the storage vessel connections. Ensure that the top of the insulation is flush with the top of the weld of the upper dished end **(C/D)**.
7. Fit the insulation and check for a precision fit **(D)**.
8. Pull off the adhesive film of the adhesive tape that has been applied to the vessel **(E)**.
9. Fix the insulating jacket onto the adhesive tape that has been applied to the storage vessel, ensuring that the holes in the insulating jacket are not warped **(E)**!
10. Starting from the top, peel away the adhesive films on both butt joint surfaces of the insulating jacket and stick the surfaces to each other whilst applying slight pressure **(E)**.
11. Place and align the shaped insulation for the upper dishing end **(F)**.
12. Remove the adhesive films on the surrounding area of the upper base insulation and at the top of the insulating jacket in turn and stick both surfaces to each other whilst applying slight pressure **(F)**.
13. Do the same with the lower base insulation and then install the outer insulation of the support ring (only 500 - 750 l).
14. Stick (all) the adhesive seams together with the adhesive tape included in the kit **(H)**.
15. Any damage to the insulation is to be masked with adhesive tape.
16. Create the shaped pieces for the insulation around the connections **(I)**.

3. Inspection & Maintenance

No liability shall be accepted for damage that is caused by failure to follow the installation and operating instructions.

The storage vessel must be installed to allow easy access for maintenance, operation, repairs or replacement. Site preparation and suitability for installation of the vessel are not the responsibility of the manufacturer or the responsible distributor. Furthermore, facilities for the secure drainage of the storage vessel in the event of any water leakage must be provided to avoid water damage.

Constant topping up of the buffer tank poses a risk of corrosion. The storage vessel must be included in the potential equalisation.

Removal

Once cooled, de-pressurize the system and remove the product from the system. Local legislation must be adhered to when disposing of the various components.

